

MODEL TR3 – LINEAR SOLUTION ENCODER



FEATURES

Integrated Heavy Duty Encoder and Measuring Wheel In One Spring Loaded Torsion Arm for Quick Wheel Pressure Adjustments Easily Installed in a Vertical, Horizontal or Upside-Down Orientation Operates Over a Variety of Surfaces at Speeds up to 3000 Feet per Minute Integrated Module Simplifies System Design, Reducing Cost

The TR3 Heavy Duty Tru-Trac™ is an integrated heavy duty encoder and spring loaded measuring wheel assembly all in one, easy-to-use, compact unit. Available in a single, or optional dual-wheel format, the TR3 Heavy Duty Tru-Trac™ is a versatile solution for tracking velocity, position or distance over a wide variety of surfaces in many industrial applications. Its spring loaded torsion arm provides a simple-to-adjust torsion load, allowing the TR3 Heavy Duty Tru-Trac™ to be mounted in any orientation, even upside-down. The TR3 Heavy Duty Tru-Trac™ housing is an all metal work horse, specifically designed to take on your toughest application environments at operating speeds up to 3000 feet per minute. Just one look and it's easy to see the TR3 Heavy Duty Tru-Trac™ is the ideal solution for countless applications.

COMMON APPLICATIONS

Lumber, Corrugated, Converting, Metal Roll Forming, Paper Monitoring, Glue Dispensing, Linear Material Monitoring, Conveyor Systems, Printing, Labeling, Mining, Construction

MODEL TR3 HEAVY DUTY TRU-TRAC™ ORDERING GUIDE

Blue type indicates price adder options. Not all configuration combinations may be available. Contact Customer Service for details.

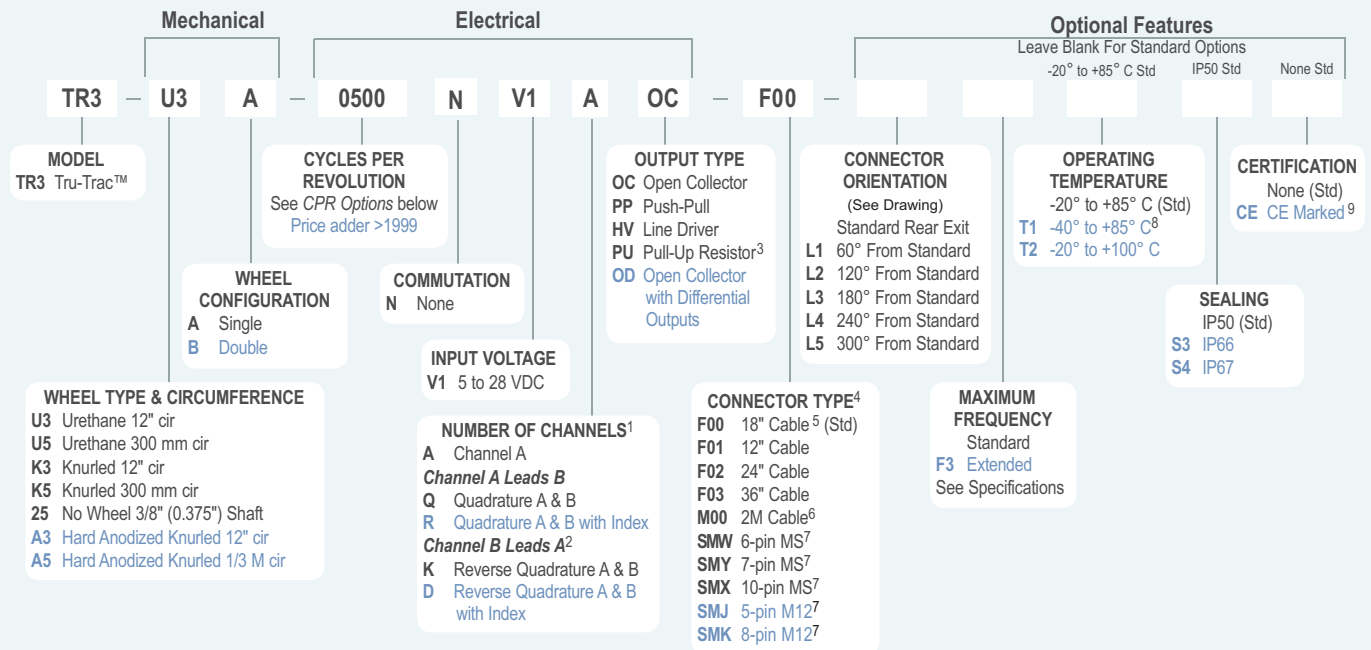

MODEL TR3 TRU-TRAC™ CPR OPTIONS

0001 thru 0189*	0198	0200	0250	0256	0300	0315	0360
0400	0500	0512	0580	0600	0750	0800	1000
1125	1200	1250	1500	1800	2000	2048	2500
2540	3000	3600	4000	4096	5000	6000	7200
8192	10,000						

*Contact Customer Service For Availability

New CPR values are periodically added to those listed. Contact Customer Service to determine all currently available values. Special disk resolutions are available upon request and may be subject to a one-time NRE fee.

NOTES:

- Contact Customer Service for non-standard index gating or phase relationship options.
- Reverse Quadrature not available with PU output type.
- With Input Voltage above 16 VDC, operating temperature is limited to 85° C.
- For mating connectors, cables, and cordsets see Encoder Accessories on page 102 or visit www.encoder.com. For Pin Configuration Diagrams, see page 107 or visit www.encoder.com.
- For non-standard English cable lengths enter 'F' plus cable length expressed in feet. Example: F06 = 6 feet of cable. Frequency above 300 kHz standard cable lengths only.
- For non-standard metric cable lengths enter 'M' plus cable length expressed in meters. Example: M06 = 6 meters of cable.
- Body Mount connector options only available with connector orientation L1 thru L5.
- Rated to -40° C during encoder operation. Storage and startup below -25° C not recommended.
- Please refer to **Technical Bulletin TB100: When to Choose the CE Option** at www.encoder.com.

MODEL TR3 TRU-TRAC™ SPECIFICATIONS

Electrical

Input Voltage..... 4.75 to 28 VDC max for temperatures up to 85° C
 4.75 to 24 VDC for temperatures between 85° C to 100° C

Input Current100 mA max (65 mA typical) with no output load

Output Format Incremental- Two square waves in quadrature with channel A leading B for clockwise shaft rotation, as viewed from the wheel side.
 See *Waveform Diagram*.

Output Types..... Open Collector- 20 mA max per channel
 Push-Pull- 20 mA max per channel
 Pull-Up- Open collector with 2.2K ohm
 Pull-Up Resistor- 20mA max per channel
 Line Driver- 20 mA max per channel
 (Meets RS 422 at 5 VDC supply)

Index..... Once per revolution.
 0190 to 10,000 CPR: Gated to output A
 0001 to 0189 CPR: Ungated
 See *Waveform Diagram*.

Max. Frequency Standard Frequency Response is
 200 kHz for CPR 1 to 2540
 500 kHz for CPR 2541 to 5000
 1 MHz for CPR 5001 to 10,000
 Extended Frequency Response (optional) is
 300 kHz for CPR 2000, 2048, 2500, and 2540

Noise Immunity..... Tested to BS EN61000-6-2; BS EN50081-2;
 BS EN61000-4-2; BS EN61000-4-3;
 BS EN61000-4-6, BS EN500811

Quadrature..... 67.5° electrical or better is typical,
 Edge Separation 54° electrical minimum at temperatures > 99° C

Waveform Symmetry .180°(±18°) electrical (single channel encoder)
 Accuracy Within 0.017° mechanical or 1 arc-minute from true position (for CPR>189).

Mechanical

Max Linear Speed 3000 FPM not to exceed a maximum shaft speed of 6000 RPM.

Shaft Material Stainless Steel

Radial Shaft Load Up to 10 lb max. Controlled by spring torsion feature

Starting Torque 1.0 oz-in typical with IP50 seal
 2.5 oz-in typical with IP66 seal and single wheel
 4.0 oz-in typical with IP66 seal and dual wheel
 7.0 oz-in typical with IP67 seal and single wheel
 14.0 oz-in typical with IP67 seal and dual wheel

Housing Powder coated aluminum

Wheel Width..... 3/4" standard

Weight..... 2.5 lb typical with single wheel
 3.0 lb typical with dual wheel

Environmental

Storage Temp -25° to +85° C

Humidity..... 98% RH non-condensing

Vibration..... 10 g @ 58 to 500 Hz

Shock..... 80 g @ 11 ms duration

Sealing..... IP50 standard; IP66 or IP67 optional

MODEL TR3 HEAVY DUTY TRU-TRAC™

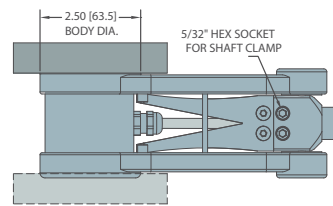
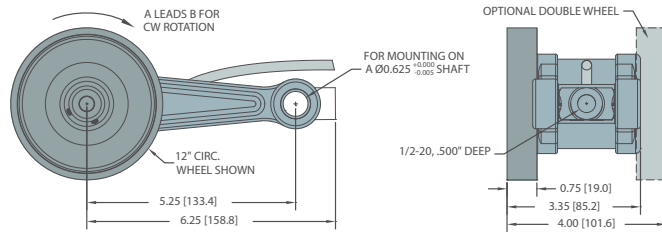

MODEL TR3 MOUNTING BRACKET

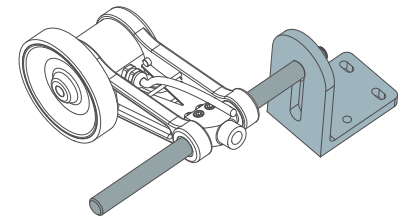
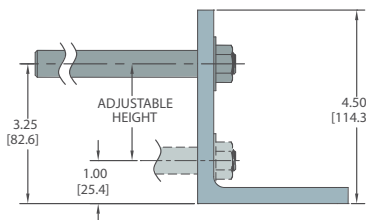
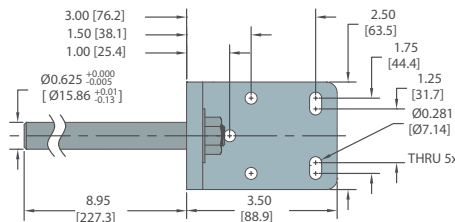

Optional Accessory Mounting Bracket (stock #176389-01) for TR3 Heavy Duty Tru-Trac™ can be ordered separately.

MODEL TR3 DOUBLE WHEEL PIVOT

ALLOWS UNIT TO ROTATE FREELY TO MAINTAIN EQUAL PRESSURE ON BOTH WHEELS, ACCOMODATING UNEVEN/ ANGLED SURFACES AND MOUNTING MISALIGNMENT

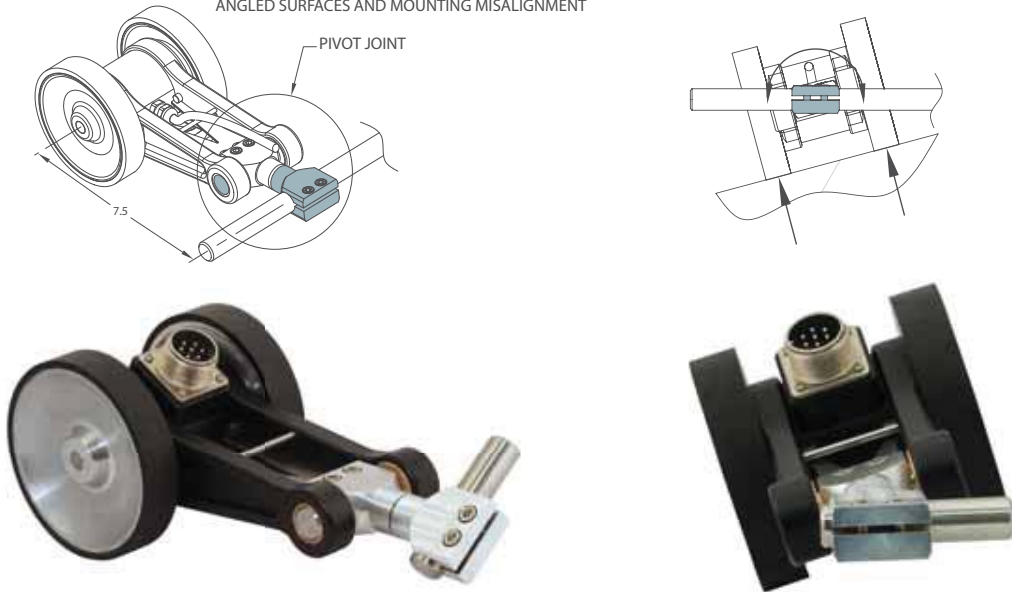

WIRING TABLE

Function	Gland Cable† Wire Color	5-pin M12**	8-pin M12**	10-pin MS	7-pin MS HV, OD	7-pin MS PU, PP, OC	6-pin MS PU, PP, OC
Com	Black	3	7	F	F	F	A, F
+VDC	White	1	2	D	D	D	B
A	Brown	4	1	A	A	A	D
A'	Yellow	--	3	H	C	--	--
B	Red	2	4	B	B	B	E
B'	Green	--	5	I	E	--	--
Z	Orange	5	6	C	--	C	C
Z'	Blue	--	8	J	--	--	--
Case	--	--	--	G	G	G	--
Shield	Bare*	--	--	--	--	--	--

*CE Option: Cable shield (bare wire) is connected to internal case.
 **CE Option: Read Technical Bulletin TB111. Available on www.encoder.com.
 †Standard cable is 24 AWG conductors with foil and braid shield.

MODEL TR3 CONNECTOR ORIENTATION

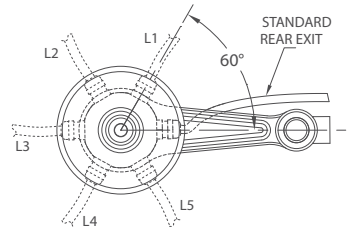

WAVEFORM DIAGRAM

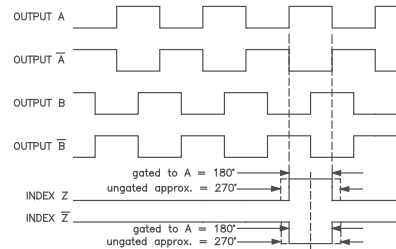

NOTE: ALL DEGREE REFERENCES ARE ELECTRICAL DEGREES.
 WAVEFORM SHOWN WITH OPTIONAL COMPLEMENTARY SIGNALS
 A-bar, B-bar FOR HV OUTPUT ONLY. CLOCKWISE ROTATION AS VIEWED FROM
 SINGLE WHEEL SIDE.